

# TITAN®

LARGEST HORSEPOWER AVAILABLE!

# T-1060

1 ¼ HORSEPOWER

### Corrosion Proof

Lifetime warranty against failure due to corrosion.

### Permanent Magnet Motor

Maximum torque instantly with the power to cut through potential jams.

### Removable Splash Guard

Removable splash guard, ideal for easy cleaning and replacement.

### Attached Power Cord

Ready to plug in.

## 3-BOLT MOUNT SYSTEM

For fast replacement of existing 3-Bolt installations.



### BIO SHIELD® Antimicrobial for ODOR PROTECTION!

Disposers are treated with an antimicrobial agent molded inside providing protection against odor causing bacteria growth.



### TORQUE MASTER®

**Balanced Grinding System:**  
A combination of computer designed and balanced components working in unison to provide superior torque grind speed and long system life.

<b>HORSEPOWER</b>	1 ¼ HP
<b>MOTOR SPEED RPM</b>	2800 RPM
<b>VOLTAGE</b>	120v
<b>AMPS</b>	7.5
<b>CYCLES</b>	60
<b>BEARINGS</b>	Permanently Lubricated, Sleeve Type
<b>MOTOR TYPE</b>	Permanent Magnet
<b>SPLASH GUARD</b>	Removable
<b>GRIND RING</b>	Stainless Steel
<b>SWIVEL IMPELLERS</b>	Cast Stainless Steel
<b>BALANCED TURNTABLE</b>	Stainless Steel
<b>BALANCED ARMATURE SHAFT</b>	Yes
<b>HOPPER</b>	Corrosion Proof
<b>DRAIN HOUSING</b>	Corrosion Proof
<b>APPLIANCE PROTECTOR</b>	Manual Reset
<b>SINK FLANGE</b>	Stainless Steel
<b>MOUNT ASSEMBLY</b>	3-Bolt
<b>SOUND SHELL</b>	Full
<b>ATTACHED POWER CORD</b>	Yes
<b>DISHWASHER CONNECTION</b>	Yes
<b>UNIT WEIGHT</b>	14.2 lb
<b>INDIVIDUAL SHIPPING WEIGHT</b>	16 lb
<b>LIFETIME CORROSION GUARANTEE</b>	Yes
<b>WARRANTY</b>	10 YEARS



### Silver Guard®

Powerful magnetic ring that captures most metal objects before they enter into the disposer chamber. This protective feature helps prevent damage to valuable cutlery. It also helps prevent damage to the disposer as well as expensive repairs caused by metal objects falling into the disposer.

### Dimensions

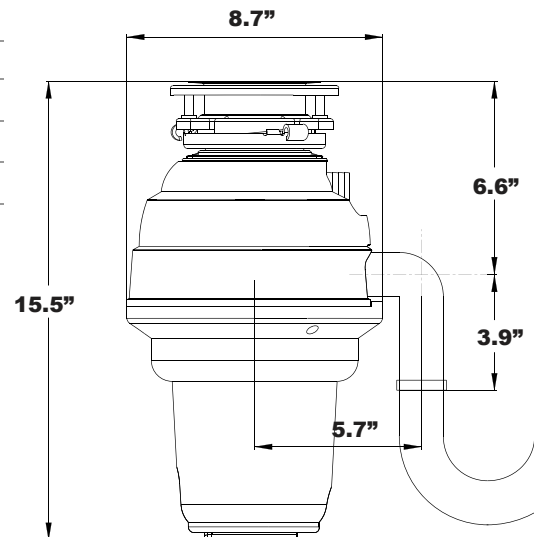

## Joneca Corporation

4332 E. La Palma Avenue, Anaheim, California 92807  
Telephone: 714.993.5997 Fax: 714.993.2126 Toll Free 1-888-8Joneca  
Website: [www.Joneca.com](http://www.Joneca.com) Email: [ContactUs@Joneca.com](mailto:ContactUs@Joneca.com)

©2019 Joneca Corporation, All Rights Reserved.

SS-T1060BK-191