

# Eco-Logic

Eco-Logic 5  
Food Waste Disposer



Eco-Logic disposers feature a 3-Bolt Mount System for fast replacement of existing 3-Bolt installations.

#### Permanent Magnet Motors

Eco-Logic motors offer maximum torque instantly with the power to cut through potential jams.

#### Removable Splash Guard

All Eco-Logic continuous feed models have a removable splash guard, ideal for easy cleaning and replacement.

#### Attached Power Cord

Ready to plug in.



#### BIO SHIELD (Antimicrobial) for ODOR PROTECTION!

Disposers are treated with an antimicrobial agent molded inside providing protection against odor causing bacteria growth.



#### The TORQUE MASTER Grinding System

is a combination of computer designed and balanced components working in unison to provide superior torque grind speed and long system life.

<b>HORSEPOWER</b>	1/2 HP
<b>MOTOR SPEED RPM</b>	2600 RPM
<b>VOLTAGE</b>	120 V
<b>AMPS</b>	4.5 A
<b>CYCLES</b>	60 Hz
<b>BEARINGS</b>	Permanently Lubricated, Sleeve Type
<b>MOTOR TYPE</b>	Permanent Magnet
<b>SPLASH GUARD</b>	Removable
<b>GRIND RING</b>	Cold Rolled Steel
<b>SWIVEL IMPELLERS</b>	Stamped Stainless Steel
<b>BALANCED TURNTABLE</b>	Cold Rolled Steel
<b>BALANCED ARMATURE SHAFT</b>	Yes
<b>HOPPER</b>	Corrosion Proof
<b>DRAIN HOUSING</b>	Corrosion Proof
<b>APPLIANCE PROTECTOR</b>	Manual Reset
<b>SINK FLANGE</b>	Stainless Steel
<b>MOUNT ASSEMBLY</b>	3-Bolt
<b>SOUND SHELL</b>	Partial
<b>ATTACHED POWER CORD</b>	Yes
<b>DISHWASHER CONNECTION</b>	Yes
<b>UNIT WEIGHT</b>	9.6 lbs.
<b>INDIVIDUAL SHIPPING WEIGHT</b>	11 lbs.
<b>LIFETIME CORROSION GUARANTEE</b>	No
<b>WARRANTY</b>	3 Years

#### Dimensions

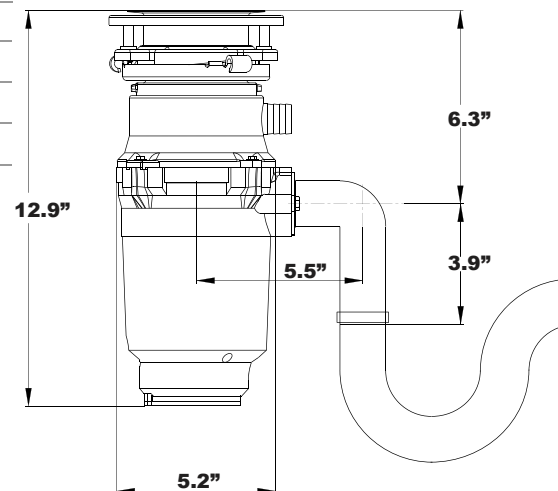

#### Joneca Corporation

4332 E. La Palma Avenue, Anaheim, California 92807  
Telephone: 714.993.5997 Fax: 714.993.2126 Toll Free 1-888-8Joneca  
Website: www.Joneca.com Email: ContactUs@Joneca.com

©2017 Joneca Corporation, All Rights Reserved.

SS-EL5-3B-181