

Eco-Logic™

Eco-Logic 4
Food Waste Disposer



Eco-Logic disposers feature a 3-Bolt Mount System for fast replacement of existing 3-Bolt installations.

Permanent Magnet Motors

Eco-Logic motors offer maximum torque instantly with the power to cut through potential jams.

Removable Splash Guard

All Eco-Logic continuous feed models have a removable splash guard, ideal for easy cleaning and replacement.

Attached Power Cord

Ready to plug in.



BIO SHIELD

(Antimicrobial) for **ODOR PROTECTION!**

Disposers are treated with an antimicrobial agent molded inside providing protection against odor causing bacteria growth.



The TORQUE MASTER Grinding System

is a combination of computer designed and balanced components working in unison to provide superior torque grind speed and long system life.

HORSEPOWER	1/3 HP
MOTOR SPEED RPM	2400 RPM
VOLTAGE	120 V
AMPS	4.5 A
CYCLES	60 Hz
BEARINGS	Permanently Lubricated, Sleeve Type
MOTOR TYPE	Permanent Magnet
SPLASH GUARD	Removable
GRIND RING	Cold Rolled Steel
SWIVEL IMPELLERS	Stamped Stainless Steel
BALANCED TURNTABLE	Cold Rolled Steel
BALANCED ARMATURE SHAFT	Yes
HOPPER	Corrosion Proof
DRAIN HOUSING	Corrosion Proof
APPLIANCE PROTECTOR	Manual Reset
SINK FLANGE	Stainless Steel
MOUNT ASSEMBLY	3-Bolt
SOUND SHELL	Partial
ATTACHED POWER CORD	Yes
DISHWASHER CONNECTION	Yes
UNIT WEIGHT	9.6 lbs.
INDIVIDUAL SHIPPING WEIGHT	11 lbs.
LIFETIME CORROSION GUARANTEE	No
WARRANTY	2 Years

Dimensions

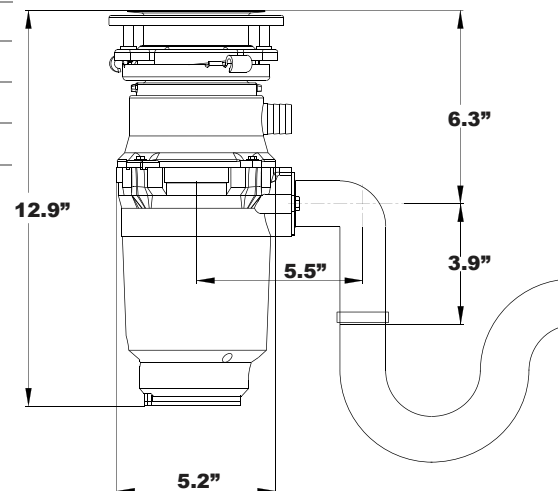

Joneca Corporation

4332 E. La Palma Avenue, Anaheim, California 92807
Telephone: 714.993.5997 Fax: 714.993.2126 Toll Free 1-888-8Joneca
Website: www.Joneca.com Email: ContactUs@Joneca.com

©2017 Joneca Corporation, All Rights Reserved.

SS-EL4-3B-181