

Eco-Logic™

Eco-Logic 10
Food Waste Disposer



Eco-Logic disposers feature a 3-Bolt Mount System for fast replacement of existing 3-Bolt installations.

Corrosion Proof

The Eco-Logic 10 model carries a lifetime warranty against failure due to corrosion.

Permanent Magnet Motors

Eco-Logic motors offer maximum torque instantly with the power to cut through potential jams.

Removable Splash Guard

All Eco-Logic continuous feed models have a removable splash guard, ideal for easy cleaning and replacement.

Attached Power Cord

Ready to plug in.

LARGEST HORSEPOWER AVAILABLE!



BIO SHIELD
(Antimicrobial)
for **ODOR PROTECTION!**
Disposers are treated with an antimicrobial agent molded inside providing protection against odor causing bacteria growth.

HORSEPOWER	1 ¼ HP
MOTOR SPEED RPM	2800 RPM
VOLTAGE	120 V
AMPS	7.5 A
CYCLES	60 Hz
BEARINGS	Permanently Lubricated, Sleeve Type
MOTOR TYPE	Permanent Magnet
SPLASH GUARD	Removable
GRIND RING	Stainless Steel
SWIVEL IMPELLERS	Cast Stainless Steel
BALANCED TURNTABLE	Stainless Steel
BALANCED ARMATURE SHAFT	Yes
HOPPER	Corrosion Proof
DRAIN HOUSING	Corrosion Proof
APPLIANCE PROTECTOR	Manual Reset
SINK FLANGE	Stainless Steel
MOUNT ASSEMBLY	3-Bolt
SOUND SHELL	Full
ATTACHED POWER CORD	Yes
DISHWASHER CONNECTION	Yes
UNIT WEIGHT	14.2 lbs.
INDIVIDUAL SHIPPING WEIGHT	16 lbs.
LIFETIME CORROSION GUARANTEE	Yes
WARRANTY	10 YEARS



The TORQUE MASTER Grinding System is a combination of computer designed and balanced components working in unison to provide superior torque grind speed and long system life.



Silver Guard
The magnetic Silver Guard captures most metal objects before they enter into the disposer chamber. This protective feature helps prevent damage to valuable cutlery. It also helps prevent damage to the disposer as well as expensive repairs caused by metal objects falling into the disposer.

Dimensions

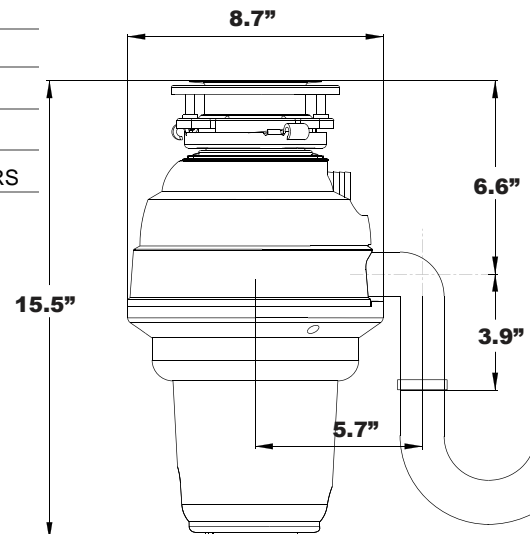

Joneca Corporation

4332 E. La Palma Avenue, Anaheim, California 92807
Telephone: 714.993.5997 Fax: 714.993.2126 Toll Free 1-888-8Joneca
Website: www.Joneca.com Email: ContactUs@Joneca.com

©2017 Joneca Corporation, All Rights Reserved.

SS-EL10-3B-181