

TITAN[®]

MODEL	T-560	T-660	T-760	T-860	T-960	T-1060
Horsepower	1/2	1/2	1/2	1/2	3/4	1 1/4
Bio Shield Antimicrobial Protection	yes	yes	yes	yes	yes	yes
TORQUE MASTER Grinding System	yes	yes	yes	yes	yes	yes
High RPM-High Torque PM Motor	yes	yes	yes	yes	yes	yes
Balanced Stainless Steel Turntable		yes	yes	yes	yes	yes
Stainless Steel Grind Ring		yes	yes	yes	yes	yes
Balanced Stainless Steel Armature	yes	yes	yes	yes	yes	yes
Corrosion Proof Grinding Chamber	yes	yes	yes	yes	yes	yes
Stainless Steel Impellers	stamped	stamped	stamped	cast	cast	cast
Speed Master Mounting System	yes	yes	yes	yes	yes	yes
Attached Power Cord & Plug	yes	yes	yes	yes	yes	yes
Built In Air Switch Available <small>(Continuous Feed Only)</small>			yes	yes	yes	yes
Batch Feed Available			yes	yes	yes	yes
Sound Insulated	no	partial	full	full	full	full
Septic Safe	yes	yes	yes	yes	yes	yes
Silver Guard <small>(Continuous Feed Only)</small>					yes	yes
RPM	2600	2600	2600	2600	2700	2800
Warranty	2 Years	3 Years	4 Years	8 Years	10 Years	10 Years



© 2011 Anaheim Marketing Intl & Joneca Corp. All Rights Reserved



AIR SWITCH POWER OPTION

The disposer is turned ON and OFF by air pressure created by pushing the button. The air travels from the button, through the air tube which is connected to the air switch inside the electrical box. The Dual Outlet Air Switch (Built-In option) available for all models except T-560 and T-660.

It provides an extra outlet for the hot water dispenser or compactor.

- Easy Installation
- Safe to use with wet hands
- Great for islands
- No wiring - Air activation

Warranty - USA & Canada Only

(International Market- Outside of USA & Canada)
Anaheim Marketing International
 4332 E. La Palma Avenue
 Anaheim, California 92807
 Telephone: 714.993.1707 Fax: 714.993.1930
 Website: www.AnaheimMarketing.com
 Email: ContactUs@AnaheimMarketing.com

(USA & Canada)
Joneca Corporation
 4332 E. La Palma Avenue
 Anaheim, California 92807
 Telephone: 714.993.5997 Fax: 714.993.2126
 Website: www.Joneca.com
 Email: ContactUs@Joneca.com

TITAN[®]

FOOD WASTE DISPOSER

EXCLUSIVE FEATURES

- **TORQUE MASTER** Balanced Grinding System
- Bio Shield Antimicrobial Protection
- **Speed Master** Mounting System
- Attached Power Cord & Plug
- Corrosion Proof Grinding Components



TITAN[®]

FOOD WASTE DISPOSERS



KITCHEN CONVENIENCE, HEALTHY ENVIRONMENT:

- Elimination Of Odors
- Cooking And Clean Up Is Easier And Faster
- No More Trips To The Garbage Container

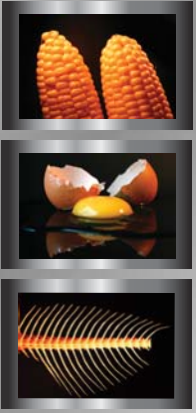

Bio Shield (Antimicrobial)
For ODOR PROTECTION!
Disposers are treated with an antimicrobial agent molded inside providing protection against odor causing bacteria growth.



The magnetic Silver Guard captures most metal objects before they enter into the disposer chamber. This protective feature helps prevent damage to valuable cutlery. It also helps prevent damage to the disposer as well as expensive repairs caused by metal objects falling into the disposer.



High Performance Grinding System. The torque master grinding system is a combination of computer designed, balanced components working in unison to provide superior torque power and maximum grinding speed.



The Speed Master Mounting System has only six components and can be installed in a few minutes without the need for tools. It is much faster than the old style 3-bolt system with its ten parts and tool requirement. Attached power cord saves time and costs.

POWER!

PROTECTION!



- **TORQUE MASTER**
- Balanced Grinding System
- 2600 RPM
- Anti-Jam Stainless Steel Impellers
- Corrosion Proof Grinding Chamber
- Balanced Turntable
- Removable Splash Guard
- Attached Power Cord & Plug
- Septic Safe

T-560_{economy}

- **TORQUE MASTER**
- Balanced Grinding System
- 2600 RPM
- Anti-Jam Stainless Steel Impellers
- Stainless Steel Grinding Components
- Corrosion Proof Grinding Chamber
- Balanced Turntable
- Removable Splash Guard
- Attached Power Cord & Plug
- Septic Safe

T-660_{standard}

- **TORQUE MASTER**
- Balanced Grinding System
- 2600 RPM
- Anti-Jam Stainless Steel Impellers
- Stainless Steel Grinding Components
- Corrosion Proof Grinding Chamber
- Sound Insulated
- Balanced Turntable
- Removable Splash Guard
- Attached Power Cord & Plug
- Septic Safe

T-760_{mid duty}

- **TORQUE MASTER**
- Balanced Grinding System
- 2600 RPM
- Anti-Jam Cast Stainless Steel Impellers
- Stainless Steel Grinding Components
- Corrosion Proof Grinding Chamber
- Full Sound Insulation
- Balanced Turntable
- Removable Splash Guard
- Attached Power Cord & Plug
- Septic Safe

T-860_{heavy duty}

- **TORQUE MASTER**
- Balanced Grinding System
- 2700 RPM
- Anti-Jam Cast Stainless Steel Impellers
- Stainless Steel Grinding Components
- Corrosion Proof Grinding Chamber
- Full Sound Insulation
- Balanced Turntable
- Removable Splash Guard
- Attached Power Cord & Plug
- Septic Safe
- Silver Guard Protection

T-960_{deluxe}

- **TORQUE MASTER**
- Balanced Grinding System
- 2800 RPM
- Anti-Jam Cast Stainless Steel Impellers
- Stainless Steel Grinding Components
- Corrosion Proof Grinding Chamber
- Full Sound Insulation
- Balanced Turntable
- Removable Splash Guard
- Attached Power Cord & Plug
- Septic Safe
- Silver Guard Protection

T-1060_{premium}

BATCH FEED POWERED Models Available.

Mid Duty, Heavy Duty, Deluxe and Premium models offer a Batch Feed version. Built in switch activated by inserting stopper. No extra switch or wiring required.



TITAN[®]



Batch Feed Units

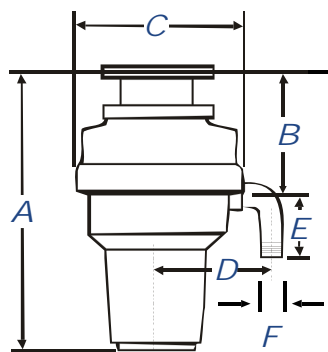

Batch Feed units add approx. 2.3"/58mm to the "A" and "B" dimension.

Measurements in inches

	Economy	Standard	Mid-Duty	Heavy Duty	Deluxe	Premium
A	13.9	13.9	14.6	14.9	16	17.3
B	6.3	6.3	7	7.3	7.3	7.3
C	5.2	5.2	7.2	8.7	8.7	8.7
D*	5.4/5.5	5.4/5.5	5.4/5.5	5.5/5.7	5.5/5.7	5.5/5.7
E*	2.7 / 3.9	2.7/3.9	2.7/3.9	2.7/3.9	2.7/3.9	2.7/3.9
F	1.5	1.5	1.5	1.5	1.5	1.5

* White Elbow/Black Elbow

Measurements in millimeters

	Economy	Standard	Mid-Duty	Heavy Duty	Deluxe	Premium
A	354	354	372	378	404	439
B	161	161	179	185	185	185
C	132	132	182	220	220	220
D*	137/140	137/140	137/140	140/144	140/144	140/144
E*	70/100	70/100	70/100	70/100	70/100	70/100
F	38	38	38	38	38	38

* White Elbow/Black Elbow



Anaheim Marketing International

4332 E. La Palma Avenue
 Anaheim, California 92807
 Telephone: 714.993.1707 Fax: 714.993.1930
 Website: www.AnaheimMarketing.com
 Email: ContactUs@AnaheimMarketing.com

(USA & Canada)



Joneca Corporation

4332 E. La Palma Avenue
 Anaheim, California 92807
 Telephone: 714.993.5997 Fax: 714.993.2126
 Website: www.Joneca.com
 Email: ContactUs@Joneca.com